

HGM1-AS02P-01-11 HGM1-AS03P-01-11 HGM1-AS04P-02-11 HGM1-AS05P-04-11 HGM1-AS06P-01-11

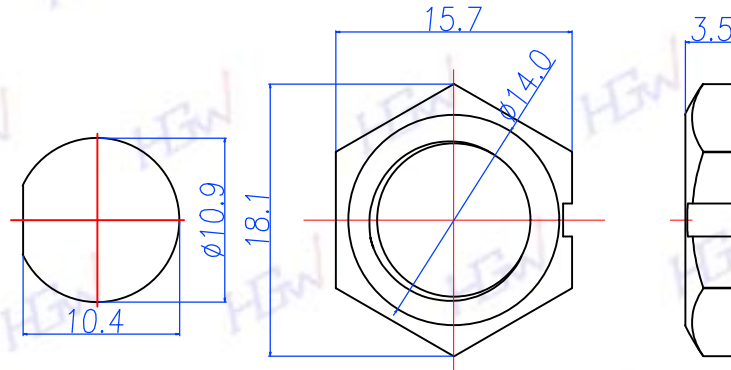

禾剛企業有限公司  
HOU GUN ENTERPRISE CO., LTD.

REV	DESCRIPTION	DATE
A		160718

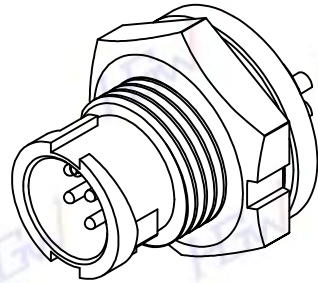
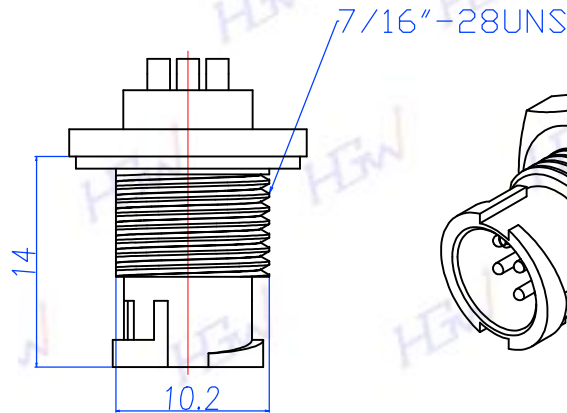

1. MATERIAL:

- 1-1. HOUSING: PA66
- 1-2. CONTACT: BRASS
- 1-3. GASKET: SILICONE
- 1-4. HEX NUT: PA66

2. FINISH

- 2-1. CONTACT: GOLD FLASH PLATED.

3. ELECTRICAL SPECIFICATION

- 3-1. RATED CURRENT: 5A(2, 3PIN)  
2A(4, 5, 6PIN)

- 3-2. RATED VOLTAGE: 250V

- 3-3. WATERPROOF: IP67

4. ENVIRONMENTAL:

- 4-1. OPERATION TEMPERATURE: -40°~105°

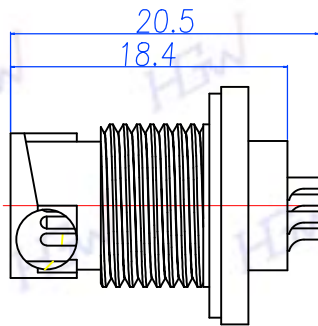
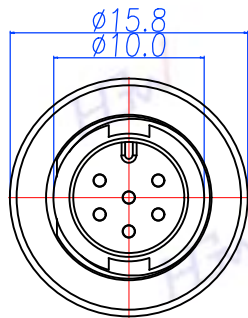

TITLE A SIZE MALE PANEL  
(WELDED WITH WIRE)

P/N:

DWG. NO: HGM1-ASPANEL

DR. Dan UNIT: mm

CH. Jason SCALE 2:1

AP. Lanny UNLESS OTHERWISE SPECIFIED TOLERANCES:

REV.	SHEET	TOLERANCES
A	1/1	X ± 0.1 XXX ± 0.03 XX ± 0.05 ANGLE ± 1°