

HGF2-BS02P-59-11

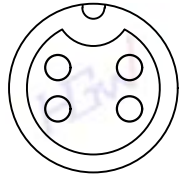

HGF2-BS04P-266-11

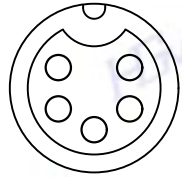

HGF2-BS05P-199-11

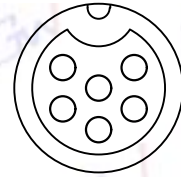

HGF2-BS06P-78-11

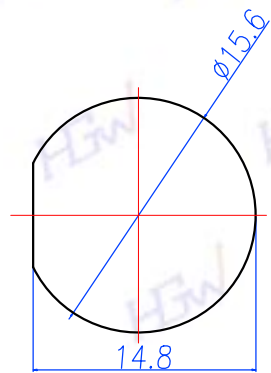
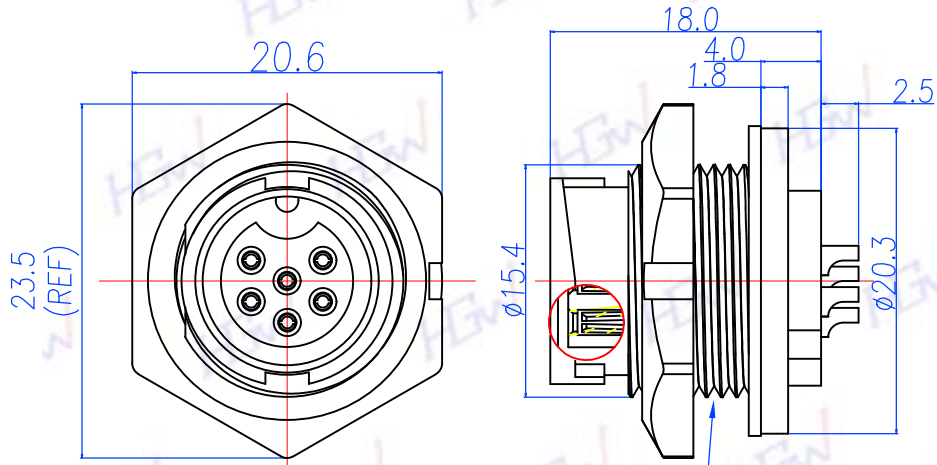

RECOMMENDED PANEL CUT-OUT

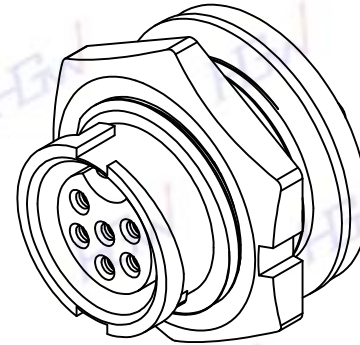
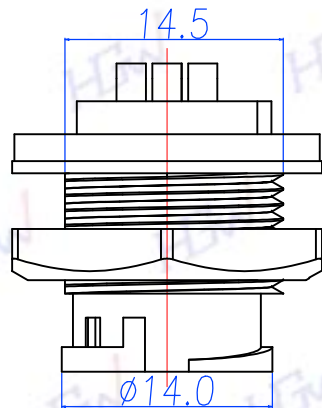

1.MATERIAL:

- 1-1.HOUSING: PA66
- 1-2.CONTACT: BRASS
- 1-3.GASKET: SILICONE
- 1-4.HEX NUT: PA66

2.FINISH

- 2-1.CONTACT: GOLD FLASH PLATED.

3.ELECTRICAL SPECIFICATION

- 3-1.RATED CURRENT: 5A
- 3-2.RATED VOLTAGE: 250V
- 3-3.WATERPROOF: IP67

4.ENVIRONMENTAL:

- 4-1.OPERATION TEMPERATURE: -40°~105°



禾剛企業有限公司
HOU GUN ENTERPRISE CO., LTD.

REV	DESCRIPTION	DATE
A		160718

TITLE B SIZE FEMALE PANEL
(WELDED WITH WIRE)

P/N:

DWG. NO: HGF2-BSPANEL5A

DR. Dan UNIT: mm

CH. Jason SCALE 2:1

AP. Lanny		UNLESS OTHERWISE SPECIFIED TOLERANCES:
REV. A	SHEET 1/1	X ± 0.1 XXX ± 0.03 XX ± 0.05 ANGLE ± 1°