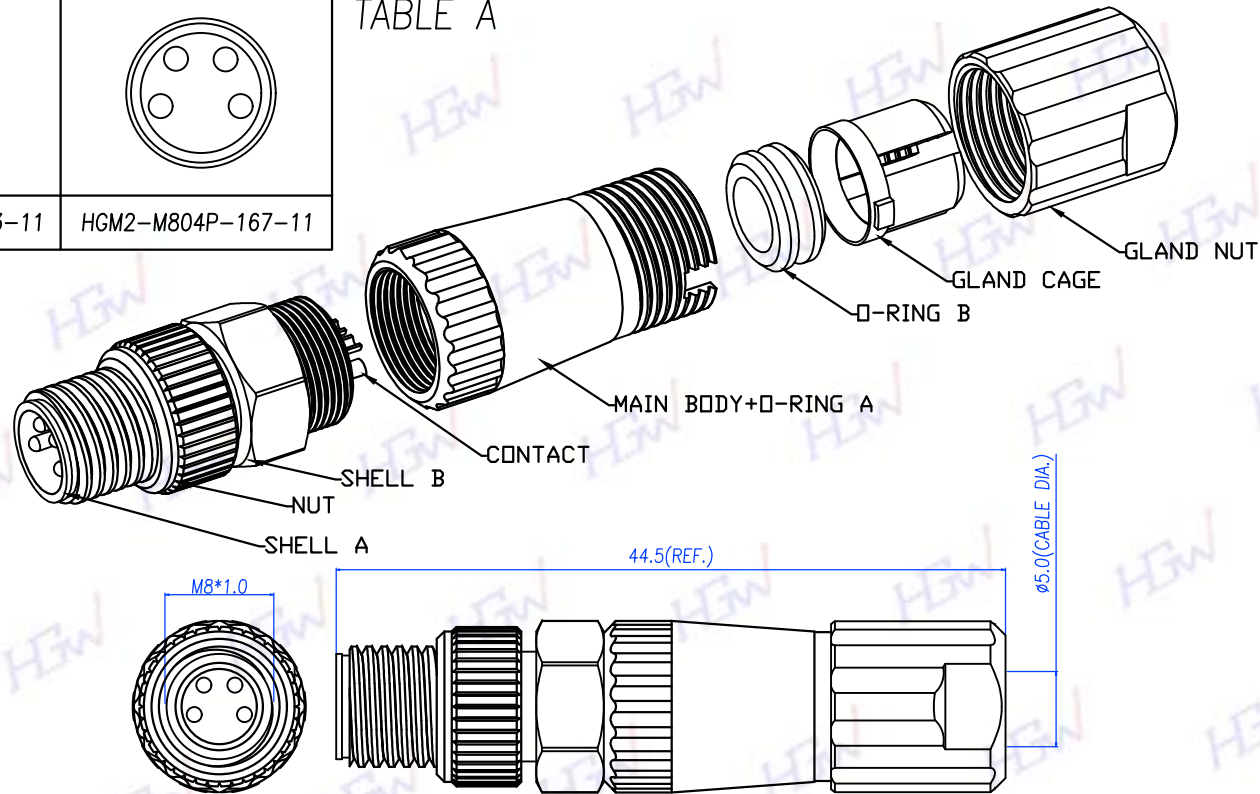

TABLE A

HGM2-M803P-103-11

HGM2-M804P-167-11



## 1.MATERIAL

## 1-1.MATERIAL A

- a.HOUSING: PBT UL94V-0 ; COLOR: BLACK
- b.CONTACT: BRASS
- c.NUT: ALUMINIUM ALLOY
- d.SHELL A: BRASS
- e.SHELL B: BRASS

## 1-2.MATERIAL B

- a.MAIN BODY: PA66 ; COLOR: BLACK
- b.O-RING A : SILICONE ; COLOR: BLACK

## 1-3.O-RING B: NBR ; COLOR: BLACK

## 1-4.GLAND CAGE: PA66 ; COLOR: WHITE

## 1-5.GLAND NUT: PA66 ; COLOR: BLACK

## 2.FINISH

## 2-1.MATERIAL A

- a.CONTACT: GOLD FLASH PLATED  
UNDER PLATED: NICKEL
- b.NUT: NICKEL PLATED
- c.SHELL A: NICKEL PLATED
- d.SHELL B: NICKEL PLATED

## 3.ELECTRICAL SPECIFICATION

- 3-1.RATED CURRENT: 4A
- 3-2.RATED VOLTAGE: 60V
- 3-3.WATERPROOF: IPX7

## 4.ENVIRONMENTAL

- 4-1.OPERATION TEMPERATURE: -20°C~85°C

禾剛企業有限公司  
HOU GUN ENTERPRISE CO., LTD.

REV	DESCRIPTION	DATE
A		181212

TITLE		M8公組裝式
P/N:		SEE TABLE A
DWG. NO:		HGM2-M8ASSY1
DR. Dan		UNIT: mm
CH. Jason	SCALE	2:1
AP. Lanny		UNLESS OTHERWISE SPECIFIED TOLERANCES:
REV. A	SHEET 1/1	X ± 0.1 XXX ± 0.03 XX ± 0.05 ANGLE ± 1°

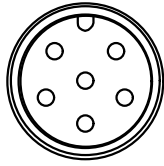
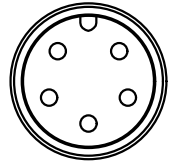
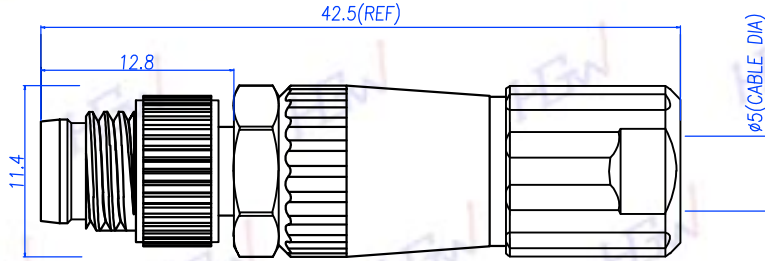
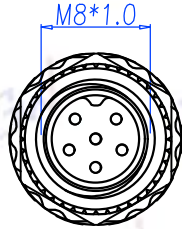
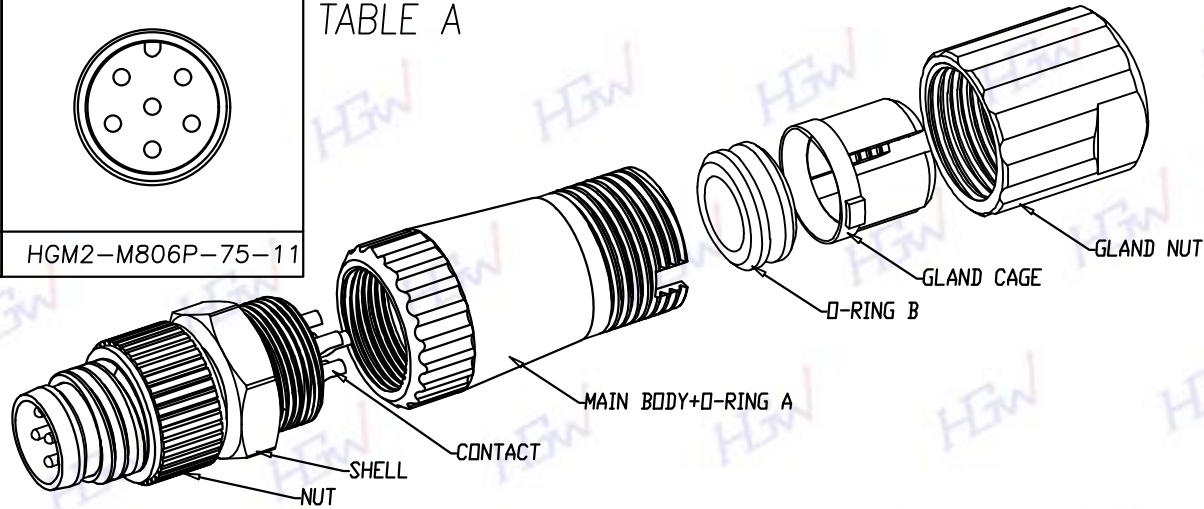

TABLE A

HGM2-M805P-167-11

HGM2-M806P-75-11



禾剛企業有限公司  
HOU GUN ENTERPRISE CO., LTD.

REV	DESCRIPTION	DATE
A		181212

1.MATERIAL

1-1.MATERIAL A

- a.HOUSING: PBT UL94V-0 ; COLOR: BLACK
- b.CONTACT: BRASS
- c.NUT: ALUMINIUM ALLOY
- d.SHELL: BRASS

1-2.MATERIAL B

- a.MAIN BODY: PA66 ; COLOR: BLACK
- b.O-RING A : SILICONE ; COLOR: BLACK

1-3.O-RING B: NBR ; COLOR: BLACK

1-4.GLAND CAGE: PA66 ; COLOR: WHITE

1-5.GLAND NUT: PA66 ; COLOR: BLACK

2.FINISH

2-1.MATERIAL A

- a.CONTACT: GOLD FLASH PLATED  
UNDER PLATED: NICKEL
- b.NUT: NICKEL PLATED
- c.SHELL: NICKEL PLATED

3.ELECTRICAL SPECIFICATION

- 3-1.RATED CURRENT: 2A
- 3-2.RATED VOLTAGE: 30V
- 3-3.WATERPROOF: IPX7

4.ENVIRONMENTAL

- 4-1.OPERATION TEMPERATURE: -20°C~85°C

TITLE		M8公組裝式
P/N:		SEE TABLE A
DWG. NO:		HGM2-M8ASSY2
DR. Dan		UNIT:mm
CH. Jason	SCALE	2:1
AP. Lanny		UNLESS OTHERWISE SPECIFIED TOLERANCES:
REV. A	SHEET 1/1	X ± 0.1 XXX ± 0.03 XX ± 0.05 ANGLE ± 1°

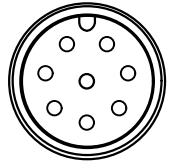

HGM2-M808P-105-11

TABLE A

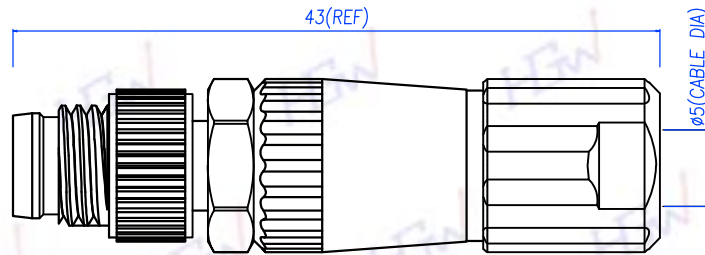
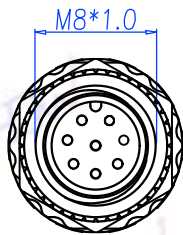
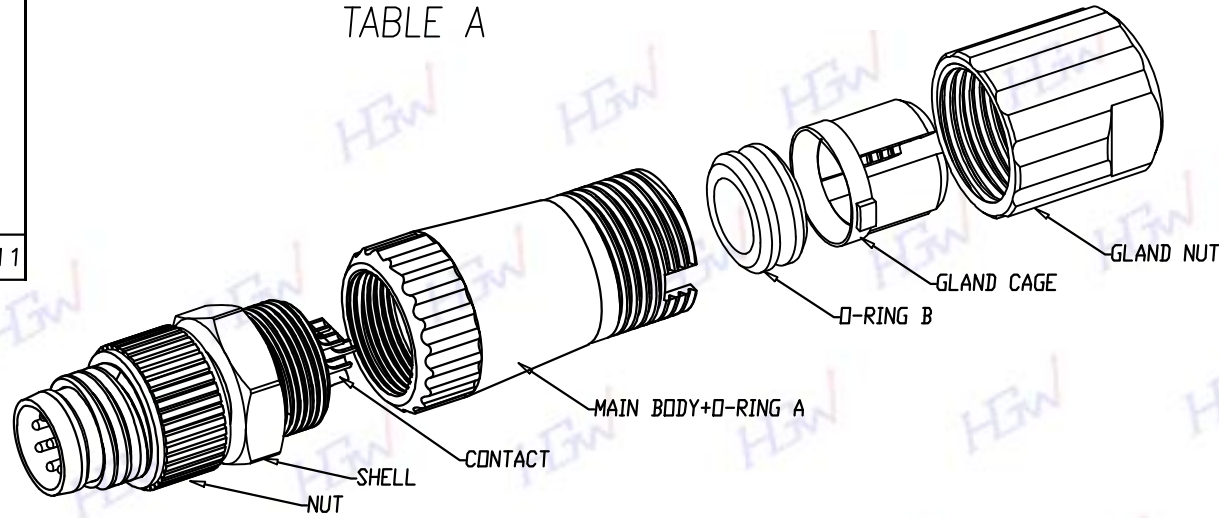

1.MATERIAL

1-1.MATERIAL A

- a.HOUSING: PA66 UL94V-0 ; COLOR: BLACK
- b.CONTACT: BRASS
- c.NUT: BRASS
- d.SHELL: BRASS

1-2.MATERIAL B

- a.MAIN BODY: PA66 ; COLOR: BLACK
- b.O-RING A : SILICONE ; COLOR: BLACK

1-3.O-RING B: NBR ; COLOR: BLACK

1-4.GLAND CAGE: PA66 ; COLOR: WHITE

1-5.GLAND NUT: PA66 ; COLOR: BLACK

2.FINISH

2-1.MATERIAL A

- a.CONTACT: GOLD FLASH PLATED  
UNDER PLATED: NICKEL
- b.NUT: NICKEL PLATED
- c.SHELL: NICKEL PLATED

3.ELECTRICAL SPECIFICATION

- 3-1.RATED CURRENT: 1.5A
- 3-2.RATED VOLTAGE: 30V
- 3-3.WATERPROOF: IPX7

4.ENVIRONMENTAL

- 4-1.OPERATION TEMPERATURE: -20°C~85°C



禾剛企業有限公司  
HOU GUN ENTERPRISE CO., LTD.

REV	DESCRIPTION	DATE
A		181212

TITLE		M8公組裝式
P/N:		SEE TABLE A
DWG. NO:		HGM2-M8ASSY3
DR. Dan		UNIT: mm
CH. Jason	SCALE	2:1
AP. Lanny		UNLESS OTHERWISE SPECIFIED TOLERANCES:
REV. A	SHEET 1/1	X ± 0.1 XXX ± 0.03 XX ± 0.05 ANGLE ± 1°